



# Slasher SST



*The IronWolf Slasher Series are attachments designed to mount on track-type tractors and enables superior mobility for a variety of construction, mining and forestry applications. The Slasher Series includes a cutter assembly and an auxiliary engine package. The cutter drum diameter is 40 inches enabling cutting depths up to 8 inches.*

## APPLICATIONS

- Clearing and mulching standing trees, brush & stumps
- Creating a clear, stable soil base
- Site clearing & site preparation, stands up to rocks in soil
- Site excavation of frozen soil with little or no mixing of sub soil into top soil

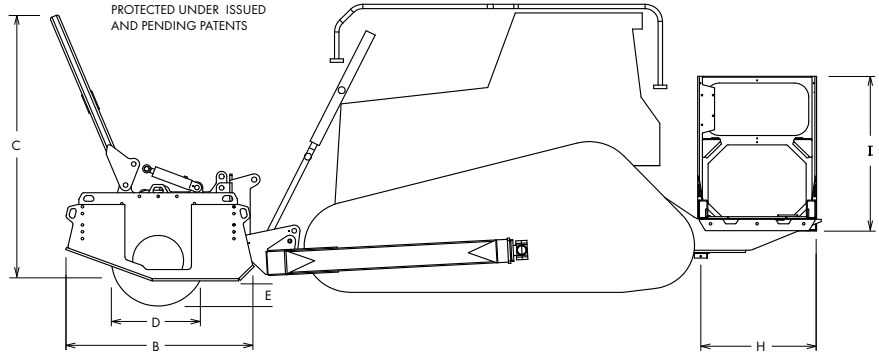
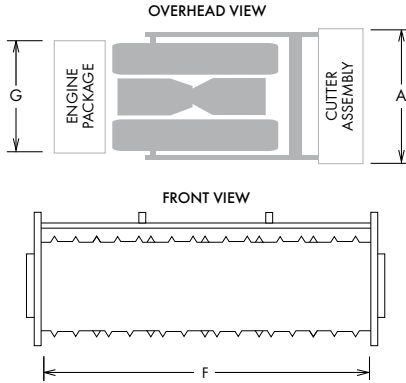

PLEASE CONTACT DISTRIBUTOR FOR MORE DETAILS REGARDING POTENTIAL CARRIER MACHINES AND INSTALLATION.

|                            | 540 SLASHER  | 1040 SLASHER  |                                     | 540 SLASHER   | 1040 SLASHER   |
|----------------------------|--|---|-------------------------------------|---|--|
| <b>Engine</b>              |  |   | <b>Dry Weights</b>                  |   |  |
| Type                       | (1) Caterpillar® C-9 turbocharger and air-to-air aftercooler | (1) Caterpillar® C-15 turbocharger and air-to-air aftercooler | Cutter Assembly                     | 18,185 lb. (8,249 kg)   | 26,594 lb. (12,063 kg)   |
| Rated Power @ 2,100 rpm    | 319 SAE net hp (238 kW)<br>350 SAE gross hp (261 kW)         | 502 SAE net hp (375 kW)<br>540 SAE gross hp (403 kW)          | Engine Package                      | 7,700 lb. (3,493 kg)  | 10,700 lb. (4,853 kg)  |
| Cylinders                  | 6  | 6   | <b>Dimensions</b>                   |   |  |
| Displacement               | 537 cu. in. (8.8 L)  | 928 cu. in. (15.2 L)  | A Width of Cutter Assembly          | 78 in. (1,981 mm)   | 138 in. (3,505 mm)   |
| Max Net Torque @ 1,400 rpm | 1,148 lb.-ft. (1,557 Nm)                                     | 1,819 lb.-ft. (2,466 Nm)                                      | B Length of Cutter Assembly         | 88 in. (2,235 mm)   | 83 in. (2,108 mm)  |
| Air Cleaner                | Dual-Stage dry type  | Dual-Stage dry type   | C Height of Cutter Assembly         | 133 in. (3,378 mm)  | 133 in. (3,378 mm)   |
| Radiator                   | Mesabi®  | Mesabi®   | D Diameter of Drum (Tooth to Tooth) | 40 in. (1,016 mm)   | 40 in. (1,016 mm)  |
| <b>Hydraulic System</b>    |  |   | E Maximum Cutting Depth             | 12 in. (305 mm)   | 12 in. (305 mm)  |
| System Relief Pressure     | 6,000 psi (41,369 kPa)                                       | 6,000 psi (41,369 kPa)  | F Cutting Width                     | 60 in. (1,524 mm)   | 120 in. (3,048 mm)   |
| Pumps                      | (1) Rexroth® 180 cc  | (2) Rexroth® 180 cc   | G Width of Engine Package           | 100 in. (2,540 mm)  | 115 in. (2,921 mm)   |
| Motors                     | (1) Rexroth® 180 cc  | (2) Rexroth® 180 cc   | H Length of Engine Package          | 46 in. (1,168 mm)   | 54 in. (1,372 mm)  |
| Maximum Flow               | 100 gpm (379 L/min)  | 200 gpm (757 L/min)   | I Height of Engine Package          | 96 in. (2,438 mm)   | 98 in. (2,489 mm)  |
| Filter, Return Oil         | 10 micron  | 10 micron   | <b>Options</b>                      |   |  |
| <b>Cutter Drives</b>       |  |   | Cutter Drum Patterns                | Optimizes production for particular applications.                         |  |
| Type                       | (1) O&K F-100  | (2) O&K F-100   | <b>Recommended Carrier Machine</b>  | CAT D5R LGP,<br>John Deere 750J LGP,<br>or equivalent dozers<br>or larger | CAT D6R LGP,<br>John Deere 850J LGP,<br>equivalent dozers<br>or larger |
| Total Ratio                | 21 to 1  | 21 to 1   |                                     |   |  |
| <b>Capacities</b>          |  |   |                                     |   |  |
| Fuel Tank                  | 90 gal. (341 L)  | 177 gal. (670 L)  |                                     |   |  |
| Hydraulic System Reservoir | 75 gal. (284 L)  | 75 gal. (284 L)   |                                     |   |  |



WWW.IRONWOLF.COM

601 HAMILTON DR. • NOBLE, OKLAHOMA 73068

V: 405.872.1890 F: 405.872.1893 • www.ironwolf.com

IRONWOLF RESERVES THE RIGHT TO MAKE CHANGES IN ENGINEERING, DESIGN AND SPECIFICATIONS; ADD IMPROVEMENTS; OR DISCONTINUE MANUFACTURING AT ANY TIME WITHOUT NOTICE OR OBLIGATION. CATERPILLAR® IS A REGISTERED TRADEMARK OF CATERPILLAR, INC. REXROTH® IS A REGISTERED TRADEMARK OF BOSCH REXROTH AG. MESABI® IS A REGISTERED TRADEMARK OF L & M RADIATOR, INC. O&K® IS A REGISTERED TRADEMARK OF ORENSTEIN & KOPPEL AKTIENGESSELLSCHAFT CORP. COPYRIGHT © 2006 IRONWOLF. ALL RIGHTS RESERVED.

